

**DIVISION: 03 00 00—CONCRETE**  
**Section: 03 16 00—Concrete Anchors**

**DIVISION: 06 00 00—WOOD, PLASTICS AND COMPOSITES**  
**Section: 06 05 23—Wood, Plastic, and Composite Fastenings**

**REPORT HOLDER:**

JENWEST ENTERPRISES LLC,

**ADDITIONAL LISTEE:**

R.H. TAMLYN & SONS, LP

**EVALUATION SUBJECT:**

**ADVANCED CONNECTOR SYSTEMS: ALSTHD/ALSTHDRJ AND ASTHD/ASTHDRJ CAST-IN-PLACE STRAP-STYLE HOLD-DOWNS**

**1.0 EVALUATION SCOPE**

**Compliance with the following codes:**

- 2015, 2012 and 2009 *International Building Code*® (IBC)
- 2015, 2012 and 2009 *International Residential Code*® (IRC)
- 2013 *Abu Dhabi International Building Code* (ADIBC)†

†The ADIBC is based on the 2009 IBC. 2009 IBC code sections referenced in this report are the same sections in the ADIBC.

**Property evaluated:**

Structural

**2.0 USES**

The Advanced Connector Systems ALSTHD/ALSTHDRJ and ASTHD/ASTHDRJ series cast-in-place strap-style hold-downs are used to connect vertical light-frame construction members (wood posts or multiple wood stud members) to concrete foundations or foundation walls. ALSTHD/ALSTHDRJ and ASTHD/ASTHDRJ are structural connectors that are cast-in-place into normalweight concrete and resist tension forces.

**2.1 Use Under the IBC:**

The ALSTHD/ALSTHDRJ and ASTHD/ASTHDRJ hold-downs may be used in buildings resisting wind and seismic forces assigned to Seismic Design Categories (SDCs) A through F in accordance with IBC Sections 1604.8.1, 1604.9, 2308.6 and 2308.7.5. The ALSTHD/ALSTHDRJ

and ASTHD/ASTHDRJ hold-downs are alternatives to cast-in-place anchors designed in accordance with Section 1901.3 of the 2015 IBC (2012 IBC Sections 1908 and 1909, or 2009 IBC Sections 1911 and 1912).

**2.2 Use Under the IRC:**

The ALSTHD/ALSTHDRJ and ASTHD/ASTHDRJ hold-downs may be used in buildings resisting wind and seismic forces assigned to Seismic Design Categories (SDCs) A through F, in accordance with IRC Sections R602.3.5, R602.10, R603.3.1 and R603.9.4 as applicable. For structures regulated under the IRC, the ALSTHD/ALSTHDRJ and ASTHD/ASTHDRJ hold-downs may be used where an engineered design is submitted in accordance with Section R301.1.3.

**3.0 DESCRIPTION**

**3.1 Series Details:**

**3.1.1 ALSTHD/ALSTHDRJ Series Strap-style Hold-downs:** The ALSTHD and ALSTHDRJ series strap-style hold-downs are manufactured from No. 14 gage cold-formed, galvanized sheet steel. The portion of the hold-down that attaches to the vertical wood member is 3 inches (76 mm) wide, and has a staggered hole fastener pattern suitable for attachment to the narrow edges of a double 2-by or larger vertical member, that is a minimum of 3 1/2 inches (89 mm) deep. The portion of the hold-down that is cast into the concrete is 2 1/2 inches (64 mm) wide, and has an 8-, 10-, or 14-inch (203-, 254-, or 356-mm) concrete embedment depth corresponding to the number in the specific product designation. The strap-style hold-downs are available in rim-joint (“RJ”) and non-rim-joint models. Rim joint models have extra length for attachment to vertical members that start above a rim joist. Table 1 lists model numbers, dimensions, embedment lengths, and fastener schedules. Figure 1 depicts installation and use with wood members.

**3.1.2 ASTHD/ASTHDRJ Series Strap-style Hold-downs:** The ASTHD and ASTHDRJ series strap-style hold-downs are manufactured from No. 12 gage cold-formed, galvanized sheet steel. The portion of the hold-down that attaches to the vertical wood member is 3 inches (76 mm) wide, and has a staggered hole fastener pattern suitable for attachment to the narrow edges of a double 2-by or larger vertical member that is a minimum of 3 1/2 inches (89 mm) deep. The portion of the hold-down that is cast into the concrete is 2 1/2 inches (64 mm) wide, and has an 8-, 10-, or 14-inch (203-, 254-, or 356-mm) concrete embedment depth corresponding to the number in the specific product designation. The strap-style hold-

downs are available in rim-joint (“RJ”) and non-rim-joint models. Rim joist models have extra length for attachment to vertical members that start above a rim joist. Table 1 lists model numbers, dimensions, embedment length, and fastener schedules. Figure 1 depicts installation and use with wood members.

### 3.2 Materials:

**3.2.1 Connector Steel:** The strap-style hold-downs described in this report are manufactured from galvanized steel complying with ASTM A653, SS designation, Grade 50, with a minimum yield strength,  $F_y$ , of 50,000 psi (345 MPa), a tensile elongation greater than 14 percent and a minimum tensile strength,  $F_u$ , of 65,000 psi (448 MPa). The strap-style hold-downs have a minimum G90 zinc coating designation in accordance with ASTM A653. The lumber treater’s recommendations or recommendations of Advanced Connector Systems, regarding minimum corrosion resistance and connection capacities of connectors used with the specific proprietary preservative-treated or fire-retardant treated lumber, must be followed. The minimum uncoated base-steel thickness for each gage is as specified in the table given below.

GAGE NO.	UNCOATED BASE-METAL THICKNESS (in.)
No. 12	0.0975
No. 14	0.0685

For SI: 1 inch = 25.4 mm.

**3.2.2 Wood:** Wood members with which the strap-style hold-downs are used must be either sawn dimensioned lumber or engineered lumber complying with an ICC-ES evaluation report. The maximum moisture content is 19 percent for sawn dimensional lumber and 16 percent for engineered lumber except as noted in Section 4.1, and the minimum specified specific gravity, or equivalent specific gravity for engineered lumber, is 0.50, such as for Douglas fir-larch.

**3.2.3 Fasteners:** Nails for wood installation must comply with ASTM F1667, as referenced in Section 2303.6 of the IBC. The following table provides the minimum dimensions and bending yield strength ( $F_{yb}$ ) for the fasteners used with the strap-style hold-downs described in this report.

FASTENER	SHANK DIAMETER (inch)	LENGTH (inches)	$F_{yb}$ (psi)
16d sinker	0.148	3 <sup>1</sup> / <sub>4</sub>	90,000
10d common	0.148	3	90,000

For SI: 1 inch = 25.4 mm, 1 psi = 6.895 kPa.

Fasteners used in contact with preservative-treated or fire-retardant-treated lumber must comply with 2015 IBC Section 2304.10.5 (Section 2304.9.5 for the 2012 and 2009 IBC), or IRC Section R317.3, as applicable.

The lumber treater’s recommendations or recommendations of Advanced Connector Systems, on minimum corrosion resistance and connection capacities of fasteners used with the specific proprietary preservative-treated or fire-retardant-treated lumber, must be followed.

**3.2.4 Concrete:** Concrete must be normalweight concrete complying with the provisions of IBC Chapter 19 or IRC Section R402.2, as applicable, and must have a minimum specified concrete compressive strength,  $f_c$  of 2,500 psi (17.2 MPa).

**3.2.5 Steel Reinforcing Bars (Rebar):** Steel reinforcement for strap-style hold-down installations must be minimum No. 4 deformed reinforcing bars complying with ACI 318, and must be located within the foundation in accordance with Section 4.2 and Figure 1 of this report.

## 4.0 DESIGN AND INSTALLATION

### 4.1 Design:

**4.1.1 Design Strength:** The allowable loads shown in the Table 1 are based on Allowable Stress Design (ASD) and include the load duration factor,  $C_D$  of 1.6. The allowable tension loads are given for different hold-down installation conditions, including locations of mid-wall, wall corner, or end-wall; load type, including SDC A&B, SDC C to F, or wind; and whether the concrete is cracked or uncracked. The allowable anchorage-to-concrete load values based on uncracked concrete are for use where analysis indicates no concrete cracking at service (unfactored) load levels.

The allowable loads in Table 1 apply to the strap-style hold-downs fastened to wood used under dry conditions and where sustained temperatures are 100°F (37.8°C) or less. If installation is in wood that has sustained exposure that exceeds these conditions, the allowable loads in this report must be adjusted by the temperature factor,  $C_t$ , specified in the *National Design Specification® for Wood Construction* (NDS). When the strap-style hold-downs are fastened to wood having a moisture content greater than 19 percent (16 percent for engineered wood products), or where wet service is expected, the allowable loads must be adjusted by the wet service factor,  $C_M$ , specified in the NDS.

IBC Section 1613.1 contains an exception that permits detached one- and two-family dwellings assigned to SDC A, B or C to be exempt from the seismic design provisions of IBC Section 1613. When this is the case, as determined by the code official, the allowable wind loads assigned to the strap-style hold-downs may be used.

**4.1.2 Serviceability:** The strap-style hold-down load ratings also consider a serviceability limit. Footnotes in Table 1 list the deflection of the strap-style hold-downs at the highest allowable tabulated loads.

### 4.2 Installation:

The strap-style hold-downs must be installed in accordance with this evaluation report and the manufacturer’s published installation instructions. In the event of a conflict between this report and the manufacturer’s published installation instructions, the more restrictive governs. Hold-down locations must comply with this report and the plans and specifications approved by the code official. For buildings regulated under the IRC and conventional light-frame construction regulated under IBC section 2308, the strap-style hold-down may be used to attach light-frame construction vertical wood framing members (posts and studs) to normalweight concrete foundations or foundation walls having the minimum thickness shown in Table 1.

Strap-style hold-downs must be installed with the minimum embedment depth,  $l_e$ , noted in Table 1 of

this report. The strap may be bent one full cycle (bent horizontally 90 degrees then bent vertically) to aid wall placement. Bending of the installed strap may cause concrete spalling behind the strap. If the spall is 1 inch (25 mm) or less, measured from the embedment line to the bottom of the spall, full loads apply. Greater spalling has not been evaluated. Any portion of the strap left exposed must be protected against corrosion by providing weather protection complying with IBC Section 1403.2 or IRC Section R703.

The tabulated allowable tension loads for strap-style hold-downs are based on anchors installed in concrete reinforced with one No. 4 deformed steel reinforcing bar located within the potential concrete failure region installed from 3 to 5 inches (76 to 127 mm) from the top of foundation. The No. 4 bar is not required to be tied or in contact with the strap-style hold-down.

#### 4.3 Special Inspection:

For the purpose of determining special inspection requirements, connectors may be considered to be special cases in accordance with Section 1705.1.1 of the IBC (Section 1704.15 of the 2009 IBC). Periodic special inspections shall be provided except where otherwise required or excepted by specific provisions of the IBC.

For installations under the IRC, special inspection is not required.

#### 5.0 CONDITIONS OF USE

The Advanced Connector Systems cast-in-place strap-style hold-downs described in this report comply with, or are a suitable alternative to what is specified in, those codes listed in Section 1.0 of this report, subject to the following conditions:

- 5.1 The strap-style hold-downs must be manufactured, identified, and installed in accordance with this report and the manufacturer's published installation instructions. A copy of the instructions must be available at the jobsite at all times during installation. In the event of conflict between this report and the manufacturers published installation instructions, the more restrictive governs.
- 5.2 Calculations and details showing compliance with this report must be submitted to the code official. The calculations must be prepared by a registered design professional where required by the statutes of the jurisdiction in which the project is to be constructed.
- 5.3 Adjustment factors noted in Section 4.1 and the applicable codes must be considered, where applicable.
- 5.4 Connected wood members and fasteners must comply, respectively, with Sections 3.2.2 and 3.2.3 of this report.
- 5.5 Use of connectors with preservative- or fire-retardant-treated lumber must be in accordance with

Section 3.2.1 of this report. Use of fasteners with preservative- or fire-retardant-treated lumber must be in accordance with Section 3.2.3 of this report.

- 5.6 Strap-style hold-downs may be installed in cracked or uncracked concrete. Cracking occurs in regions of concrete where analysis indicates cracking may occur ( $f_t > f_{cr}$ ) subject to the conditions of this report.
- 5.7 Special inspection must be provided in accordance with Section 4.3 of this report.
- 5.8 Strap-style hold-downs are limited to resisting tension loads resulting from wind or earthquake loads only.
- 5.9 The supporting concrete member must be designed by others to resist the applied uplift force, as applicable, by the hold-down.
- 5.10 The connectors are manufactured under a quality control program with inspections by ICC-ES.

#### 6.0 EVIDENCE SUBMITTED

Data in accordance with the ICC-ES Acceptance Criteria for Cast-in-place Cold-formed Steel Connectors in Concrete for Light-frame Construction (AC398), dated June 2017.

#### 7.0 IDENTIFICATION

The Advanced Connector Systems cast-in-place strap-style hold-downs described in this report are identified with a die-stamped label indicating the name of the manufacturer [either Advanced Connector Systems (ACS) or R.H. Tamlyn & Sons (Tamlyn)], the model number, and the evaluation report number (ESR-3635).

- 7.1 The report holder's contact information is the following:

**JENWEST ENTERPRISES LLC,  
DBA ADVANCED CONNECTOR SYSTEMS  
321 SOUTH 1240 WEST #15  
LINDON, UTAH 84042  
(801) 735-1178  
[www.acstough.com/](http://www.acstough.com/)  
[info@acstough.com](mailto:info@acstough.com)**

- 7.2 The Additional Listee's contact information is the following:

**R.H. TAMLYN & SONS, LP  
13623 PIKE ROAD  
STAFFORD, TEXAS 77477-5103  
(281) 499-9604  
[www.tamlyn.com/](http://www.tamlyn.com/)  
[info@tamlyn.com](mailto:info@tamlyn.com)**

**TABLE 1—ALSTHD and ASTHD SERIES STRAP-STYLE HOLD-DOWN ALLOWABLE STRESS DESIGN (ASD) LOADS INSTALLED ON WOOD VERTICAL MEMBERS – 2,500 psi CONCRETE<sup>1,3,6,8,9</sup>**

SDC A & B --Allowable Tension Loads For Doug Fir & Southern Pine (160) <sup>4,5</sup>														
Min. Stem Wall Width (in)	Model No.		Dimensions (in.)					Req'd Nails <sup>2,7</sup>	Allowable Tension Loads					
	Standard	Rim Joist	Standard		Rim Joist		le		Non-Cracked			Cracked		
			Length (L)	S	Length (L)	S			Midwall	Corner	Endwall	Midwall	Corner	Endwall
6	ALSTHD8	ALSTHD8RJ	19 1/8	5 1/2	32 3/8	18 1/8	8	20-16d Sinkers	3985	2835	1805	3780	2630	1620
	ASTHD10	ASTHD10RJ	24 3/8	4 1/8	39 3/8	19 1/8	10	24-16d Sinkers	4640	3940	2300	4640	3940	2300
	ASTHD14	ASTHD14RJ	27 1/2	5 1/4	41 3/8	18 1/8	14	32-16d Sinkers	7010	5780	3940	7010	5780	3940
8	ALSTHD8	ALSTHD8RJ	19 1/8	5 1/2	32 3/8	18 1/8	8	20-16d Sinkers	3985	2835	2285	3780	2630	2070
	ASTHD10	ASTHD10RJ	24 3/8	4 1/8	39 3/8	19 1/8	10	24-16d Sinkers	5850	3885	2995	5850	3885	2995
	ASTHD14	ASTHD14RJ	27 1/2	5 1/4	41 3/8	18 1/8	14	32-16d Sinkers	7010	5780	4100	7010	5780	4100
SDC C through F--Allowable Tension Loads For Doug Fir & Southern Pine (160) <sup>4,5</sup>														
Min. Stem Wall (in)	Model No.		Dimensions (in.)					Req'd Nails <sup>2,7</sup>	Allowable Tension Loads					
	Standard	Rim Joist	Standard		Rim Joist		le		Non-Cracked			Cracked		
			Length (L)	S	Length (L)	S			Midwall	Corner	Endwall	Midwall	Corner	Endwall
6	ALSTHD8	ALSTHD8RJ	19 1/8	5 1/2	32 3/8	18 1/8	8	16-16d Sinkers	3090	2025	1290	2835	1970	1215
	ASTHD10	ASTHD10RJ	24 3/8	4 1/8	39 3/8	19 1/8	10	18-16d Sinkers	3480	2815	1640	3480	2815	1640
	ASTHD14	ASTHD14RJ	27 1/2	5 1/4	41 3/8	18 1/8	14	24-16d Sinkers	5010	4130	2815	5010	4130	2815
8	ALSTHD8	ALSTHD8RJ	19 1/8	5 1/2	32 3/8	18 1/8	8	16-16d Sinkers	3090	2025	1630	2835	1970	1555
	ASTHD10	ASTHD10RJ	24 3/8	4 1/8	39 3/8	19 1/8	10	20-16d Sinkers	4180	2775	2140	4180	2775	2140
	ASTHD14	ASTHD14RJ	27 1/2	5 1/4	41 3/8	18 1/8	14	28-16d Sinkers	5010	4130	2925	5010	4130	2925
Wind --Allowable Tension Loads For Doug Fir & Southern Pine (160) <sup>4,5</sup>														
Min. Stem Wall (in)	Model No.		Dimensions (in.)					Req'd Nails <sup>2,7</sup>	Allowable Tension Loads					
	Standard	Rim Joist	Standard		Rim Joist		le		Non-Cracked			Cracked		
			Length (L)	S	Length (L)	S			Midwall	Corner	Endwall	Midwall	Corner	Endwall
6	ALSTHD8	ALSTHD8RJ	19 1/8	5 1/2	32 3/8	18 1/8	8	20-16d Sinkers	3925	2730	1680	3235	2250	1385
	ASTHD10	ASTHD10RJ	24 3/8	4 1/8	39 3/8	19 1/8	10	24-16d Sinkers	3970	3561	2110	3970	3560	2110
	ASTHD14	ASTHD14RJ	27 1/2	5 1/4	41 3/8	18 1/8	14	32-16d Sinkers	7010	5590	3510	7010	5590	3510
8	ALSTHD8	ALSTHD8RJ	19 1/8	5 1/2	32 3/8	18 1/8	8	20-16d Sinkers	3925	2730	2250	3235	2250	1770
	ASTHD10	ASTHD10RJ	24 3/8	4 1/8	39 3/8	19 1/8	10	28-16d Sinkers	5850	3665	2925	5850	3665	2925
	ASTHD14	ASTHD14RJ	27 1/2	5 1/4	41 3/8	18 1/8	14	32-16d Sinkers	7010	5590	3870	7010	5590	3870

For SI: 1 inch = 25.4 mm, 1 lb = 4.45 N, 1 psi = 6.895 kPa.

<sup>1</sup> See Figure 1 for L and S dimension and installation requirements.

<sup>2</sup> 10d Common (3-inch long x 0.148-inch diameter) may be used with no load reduction.

<sup>3</sup> Deflection at highest allowable loads (ASD) are as follows: ALSTHD8 = 0.072-inch, ASTHD10 = 0.067-inch, ASTHD14 = 0.084-inch.

<sup>4</sup> Multiply seismic and wind ASD loads by 1.43 and 1.67, respectively, to obtain LRFD capacities. LRFD for ALSTHD8 / ALSTHD8RJ, ASTHD10 / ASTHD10RJ, and ASTHD14 / ASTHD14RJ must not exceed 5140 pounds, 7700 pounds, and 8250 pounds, respectively, with time effect factor λ of 1.0.

<sup>5</sup> In accordance with IBC Section 1613.1, detached one- and two-family dwellings in SDC C may use, subject to the building official, design loads for Wind.

<sup>6</sup> Minimum center-to-center spacing is 3 times the required embedment ( $S_{min}=3 \times l_e$ ) for the hold-downs acting in tension simultaneously. Mid-wall location is based on  $1.5 \times l_e$  end distance.

<sup>7</sup> Nail quantities are based on 2015 NDS nail calculations using the SG of 0.5. Engineered wood must comply with Section 3.2.2.

<sup>8</sup> See Sections 3.2.1 and 3.2.3 of this report for installations with treated wood. Reduction in connection strength due to chemical treatment shall be applied to the allowable tension loads based on data from lumber treater.

<sup>9</sup> Wood studs must be minimum 2-2x4 with nails installed into the narrow face.

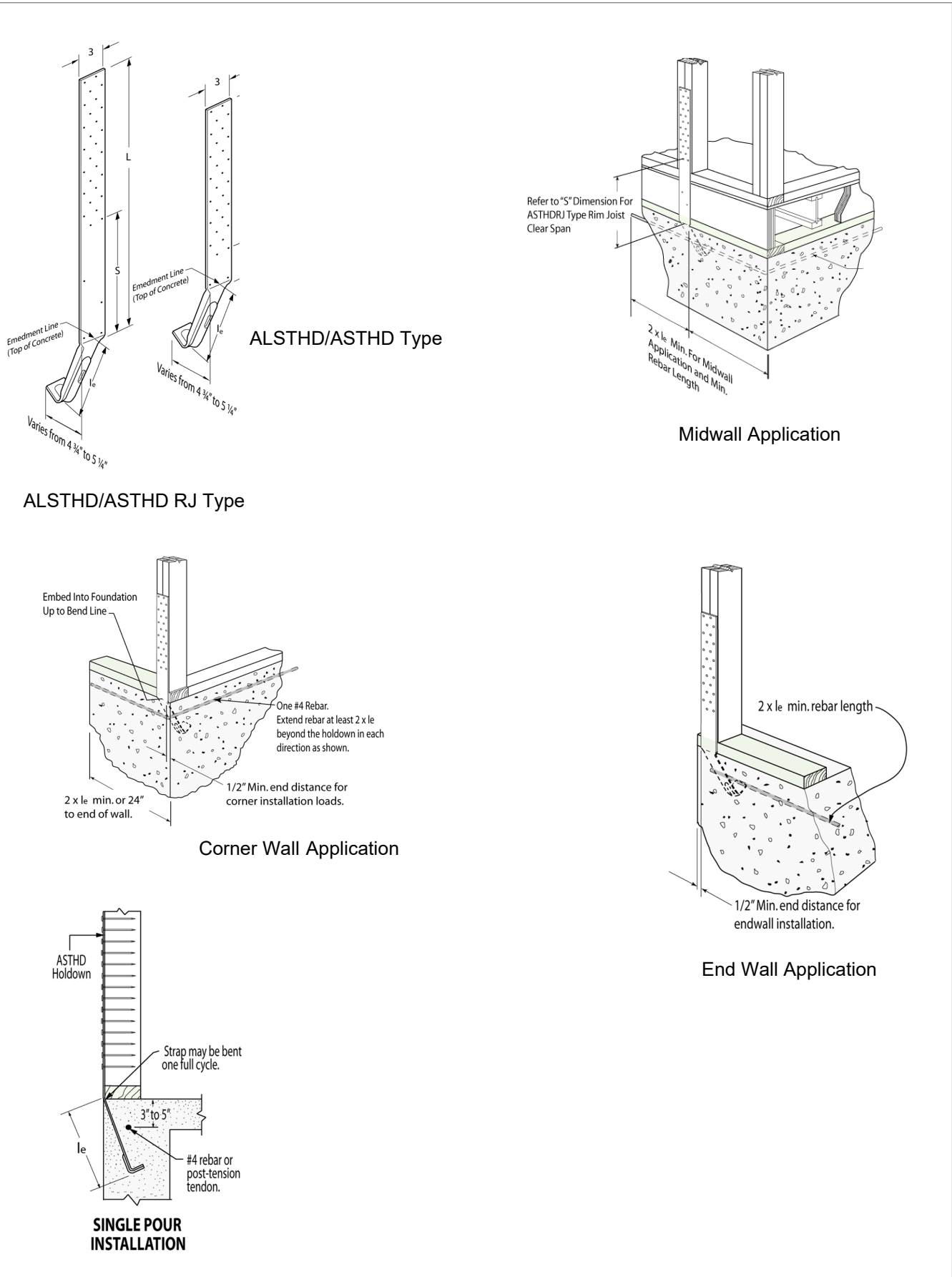

FIGURE 1—INSTALLATION APPLICATIONS